

Security Policy Review: Credible Event Management

Appendix 4 – Busbar Configurations

December 2009



SYSTEM OPERATOR

Keeping the energy flowing

TRANSPower



NOTICE

COPYRIGHT © 2009 TRANSPOWER New Zealand LIMITED

ALL RIGHTS RESERVED

The information contained in the report is protected by copyright vested in Transpower New Zealand Limited ("Transpower"). The report is supplied in confidence to you solely for your information. No part of the report may be reproduced or transmitted in any form by any means including, without limitation, electronic, photocopying, recording, or otherwise, without the prior written permission of Transpower. No information embodied in the report which is not already in the public domain shall be communicated in any manner whatsoever to any third party without the prior written consent of Transpower.

Any breach of the above obligations may be restrained by legal proceedings seeking remedies including injunctions, damages and costs.

LIMITATION OF LIABILITY/DISCLAIMER OF WARRANTY

Transpower make no representation or warranties with respect to the accuracy or completeness of the information contained in the report. Unless it is not lawfully permitted to do so, Transpower specifically disclaims any implied warranties of merchantability or fitness for any particular purpose and shall in no event be liable for, any loss of profit or any other commercial damage, including but not limited to special, incidental, consequential or other damages.

Version	Date	Change
1	October 2009	Draft
2	December 2009	Final

TABLE OF CONTENTS

APPENDIX 4 – BUSBAR CONFIGURATIONS	4
<i>Summary of Busbar Configurations</i>	4
<i>220kV Busbar Configurations and Consequences</i>	8
<i>110kV Busbar Configurations and Consequences</i>	10
<i>66kV Busbar Configurations and Consequences</i>	12

Appendix 4 – Busbar Configurations

Summary of Busbar Configurations

Six different types of busbar configuration have been identified, each has different level of asset redundancy accommodated and operational flexibility. As busbar terminology adopted by international transmission owners can vary, the terminology used within this report is introduced in this appendix. The following busbar configurations are illustrated and described below.

- Single Busbar or 2x Single Busbar(s)
- Sectionalised Busbar
- Meshed System
- Breaker and a Half
- Double Busbar
- Double Breaker – Double Busbar

Summary of Busbar Configurations

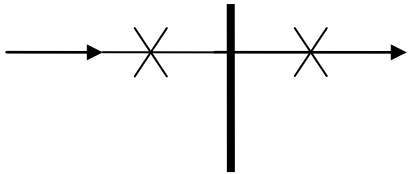
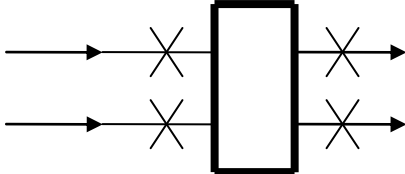
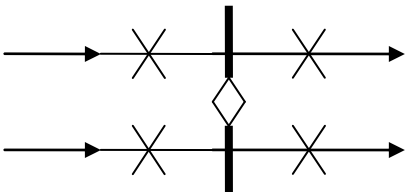
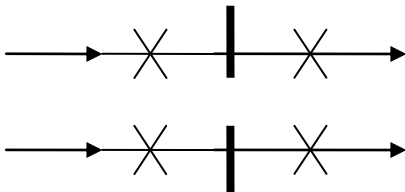
Configuration: <i>Single Busbar</i>	
	
<p>A <i>single bus</i> section to which all incomers and feeders are connected. Single busbars include those that have section disconnectors that are closed during normal operating conditions. Since there are no bus section circuit breakers all the circuits connected the bus will be lost following the loss of the bus section.</p>	
Configuration: <i>2 x Single Busbar</i>	
	
<p>Two <i>single busbars</i> or bus sections at a substation, incomers and feeders are directly connected to one bus section, without the flexibility of connecting directly to the other. This arrangement includes two bus sections that are separated via an open disconnector. Since there are no bus section circuit breakers all circuits connected to a bus section will be lost following the loss of that bus section.</p>	

Summary of Busbar Configurations

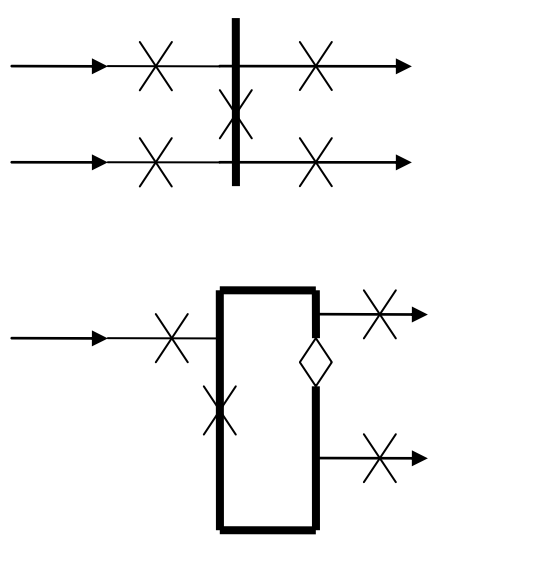
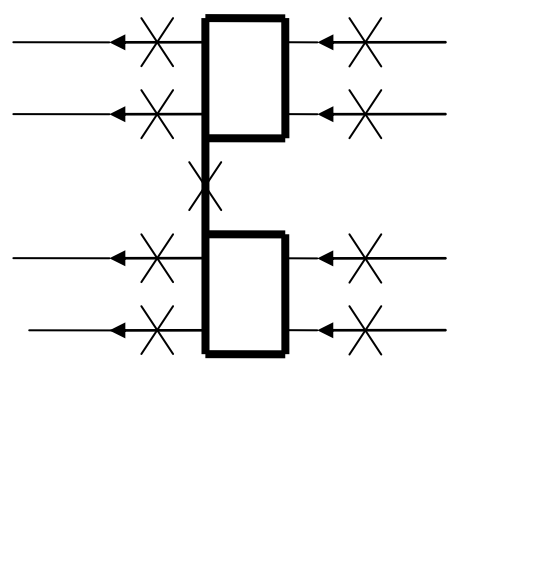
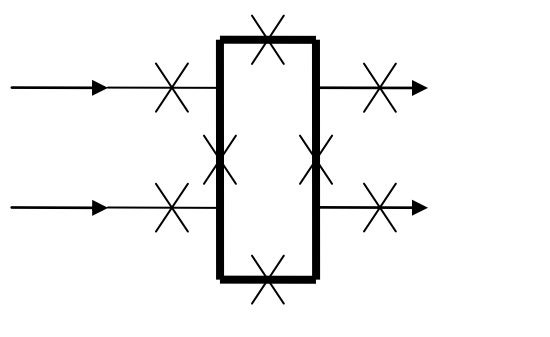
<p>Configuration: Sectionalised Busbar</p>	
	
<p><i>The busbar may be split into more than one section by the operation of bus section breakers. Where there is more than one bus section, the loss of a bus section may lead to the isolation of adjacent bus sections. Most busbars with this configuration have bus zone protection that will trip the section breakers post-event and isolate the affected bus section. All circuits connected to the affected bus section will be lost following the loss of the bus section.</i></p>	
<p>Configuration: Meshed System (4 sections)</p>	
	
<p><i>The busbar may be split into more than one section by the operation of bus section breakers. Where there is more than one bus section, the loss of a single bus section will not lead to the isolation of adjacent bus sections. Most busbars with this configuration have bus zone protection that will trip the section breakers post-event and isolate the affected bus section. All circuits connected to the affected bus section will be lost following the loss of the bus section.</i></p>	

Summary of Busbar Configurations

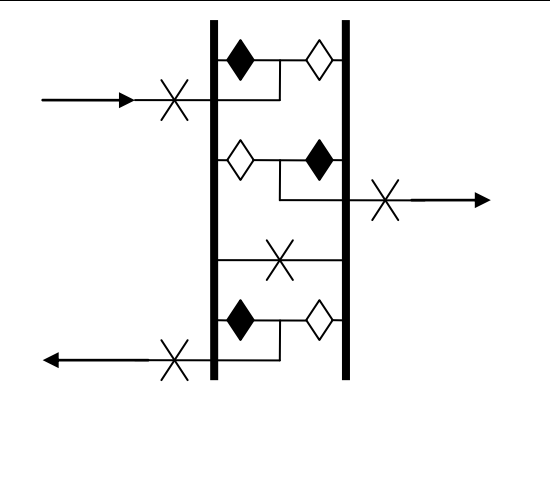
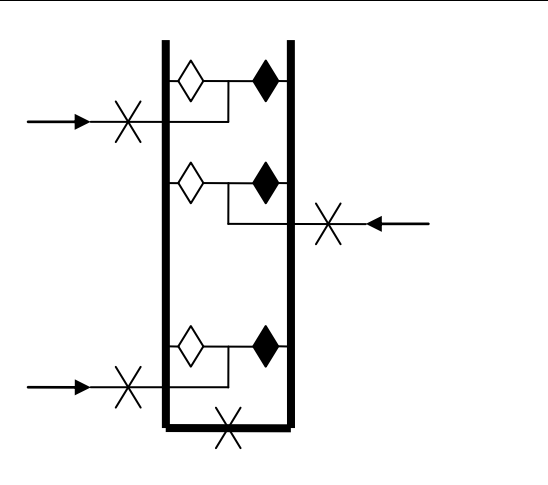
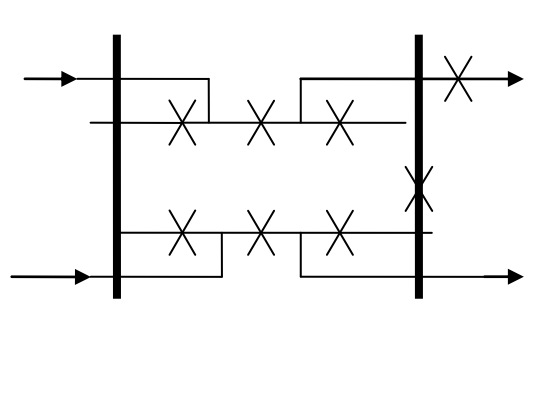
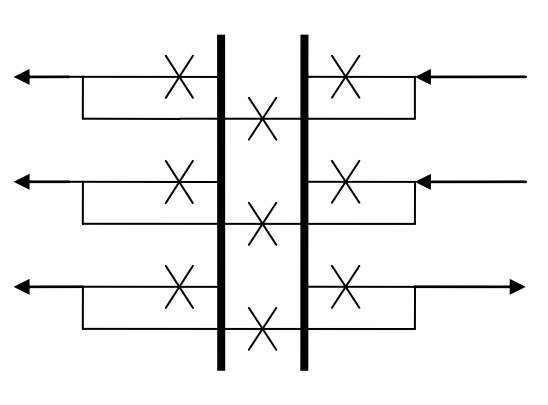
<p>Configuration: <i>Double Busbar</i></p>	
	
<p><i>The substation comprises of more than one busbar or bus section, incomers and feeders may be connected to one of two bus section via the operation of disconnectors. For each feeder there is on average 1 circuit breaker. All circuits connected to the affected bus section will be lost following the loss of the bus section.</i></p>	
<p>Configuration: <i>Breaker and a Half</i></p>	
	
<p><i>The substation comprises of more than one busbar or bus section, incomers and feeders may be connected to one of two bus section via the operation of circuit breakers. For each feeder there are on average 1.5 associated circuit breakers. Busbars with this configuration have bus zone protection that will trip the section breakers post-event and isolate the affected bus section. All circuits connected to the affected bus section will be transferred to the remaining bus section.</i></p>	

Summary of Busbar Configurations

Configuration: Double Breaker – Double Busbar

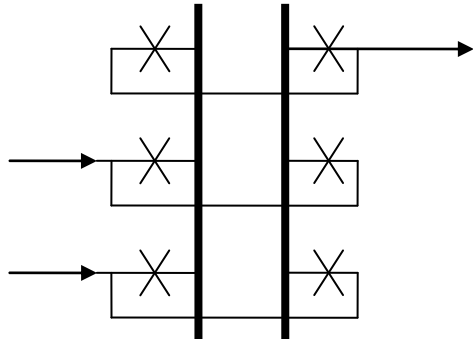

The substation comprises of more than one busbar or bus section, incomers and feeders may be connected to one of two bus sections via the operation of circuit breakers. For each feeder there are on average 2 associated circuit breakers. Busbars with this configuration have bus zone protection that will trip the section breakers post-event and isolate the affected bus section. All circuits connected to the affected bus section will be transferred to the remaining bus section.

220kV Busbar Configurations and Consequences

220 kV Busbar Configuration	Number of Substation Sites					
	Indirect Loss of Load (costed)	Loss of Load	Loss of Generation	No Issues	Loss of Load + Generation	Total
<i>Single busbar</i>	2	6	7	1	0	16.00
<i>2 x single busbar</i>	0	0	1	6	0	7.00
<i>Sectionalised single busbar</i>	11	0	6	6	2	25.00
<i>Double busbar</i>	8	0	3	7	0	18.00
<i>Breaker and a half</i>	1	0	1	4	0	6.00
<i>Meshed system</i>	1	0	0	0	0	1.00

220 kV Busbar Configuration	Percentage of Substation Sites					
	Indirect Loss of Load (costed)	Loss of Load	Loss of Generation	No Issues	Loss of Load + Generation	Total
<i>Single busbar</i>	2.74	8.22	9.59	1.37	0.00	21.92
<i>2 x single busbar</i>	0.00	0.00	1.37	8.22	0.00	9.59
<i>Sectionalised single busbar</i>	15.07	0.00	8.22	8.22	2.74	34.25
<i>Double busbar</i>	10.96	0.00	4.11	9.59	0.00	24.66
<i>Breaker and a half</i>	1.37	0.00	1.37	5.48	0.00	8.22
<i>Meshed system</i>	1.37	0.00	0.00	0.00	0.00	1.37

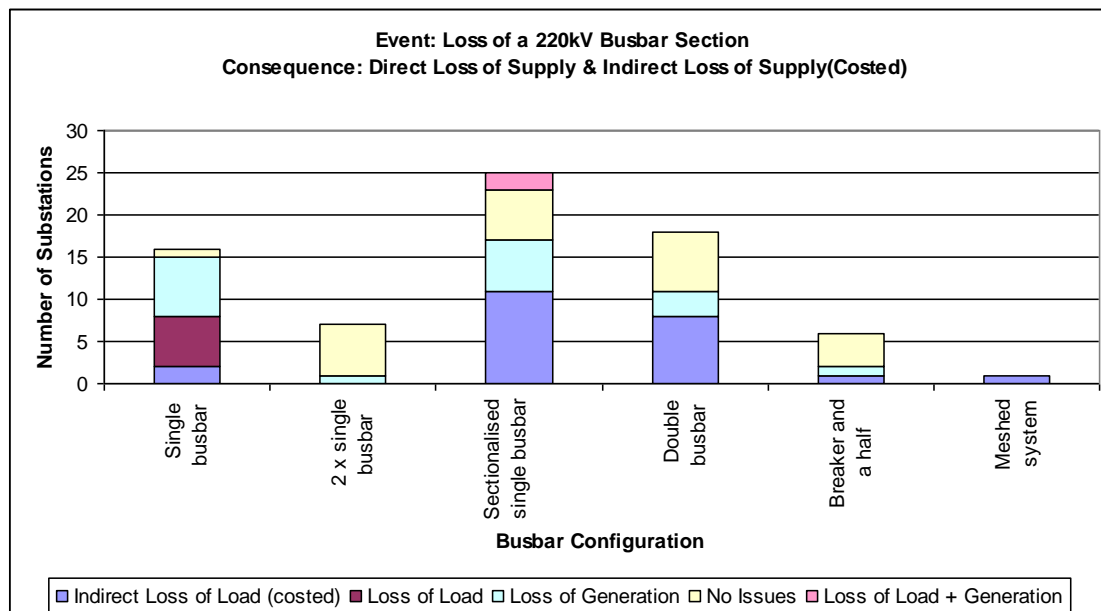

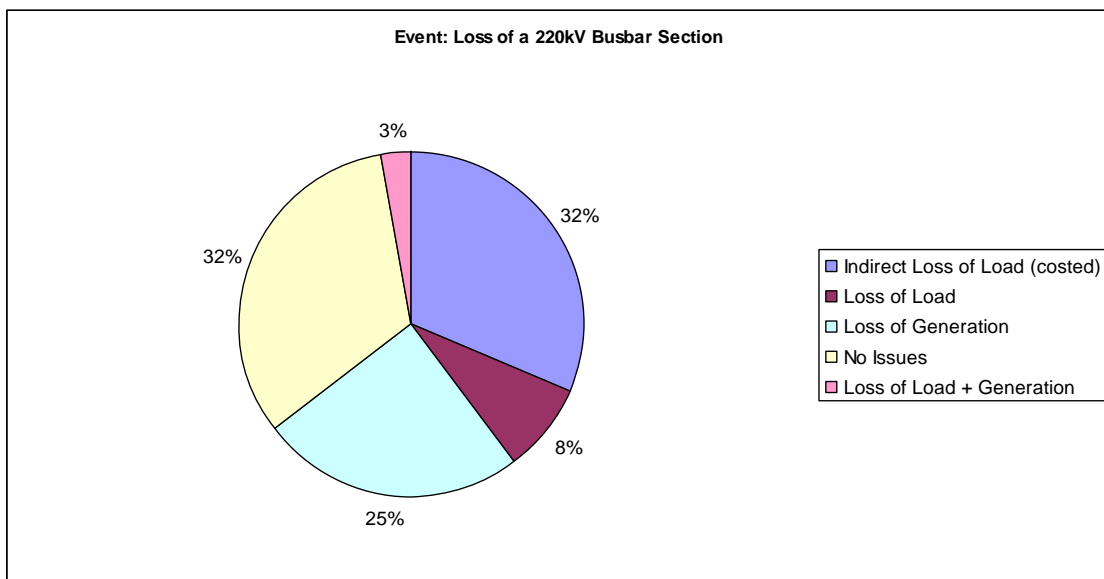
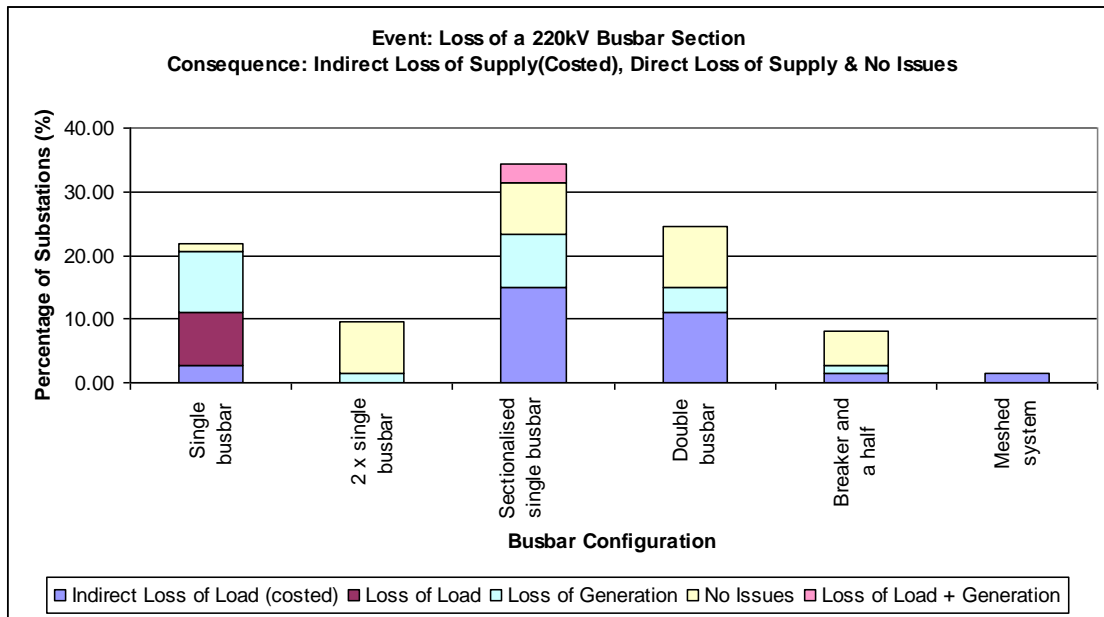

110kV Busbar Configurations and Consequences

110 kV Busbar Configuration	Number of Substation Sites					
	Indirect Loss of Load (costed)	Loss of Load	Loss of Generation	No Issues	Loss of Load + Generation	Total
<i>Single busbar</i>	6	38	3	1	0	48
<i>2 x single busbar</i>	1	1	0	12	0	14
<i>Sectionalised single busbar</i>	3	5	2	8	1	19
<i>Double busbar</i>	3	0	0	2	1	6
<i>Breaker and a half</i>	0	0	0	0	0	0
<i>Meshed system</i>	0	0	0	0	0	0
110 kV Busbar Configuration	Percentage of Substation Sites					
	Indirect Loss of Load (costed)	Loss of Load	Loss of Generation	No Issues	Loss of Load + Generation	Total
<i>Single busbar</i>	6.90	43.68	3.45	1.15	0.00	55.17
<i>2 x single busbar</i>	1.15	1.15	0.00	13.79	0.00	16.09
<i>Sectionalised single busbar</i>	3.45	5.75	2.30	9.20	1.15	21.84
<i>Double busbar</i>	3.45	0.00	0.00	2.30	1.15	6.90
<i>Breaker and a half</i>	0.00	0.00	0.00	0.00	0.00	0.00
<i>Meshed system</i>	0.00	0.00	0.00	0.00	0.00	0.00

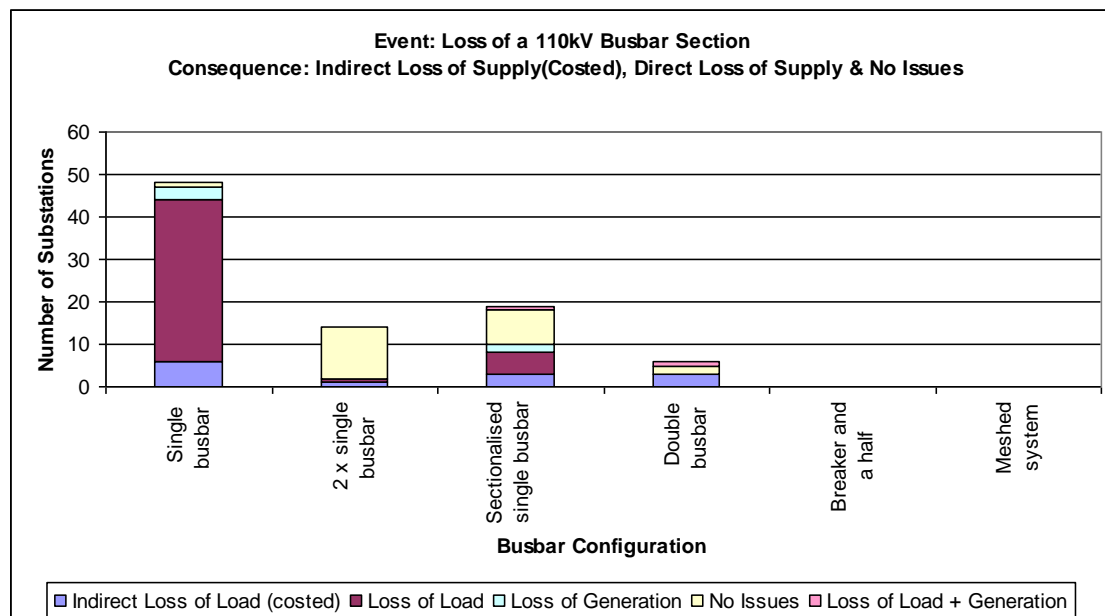

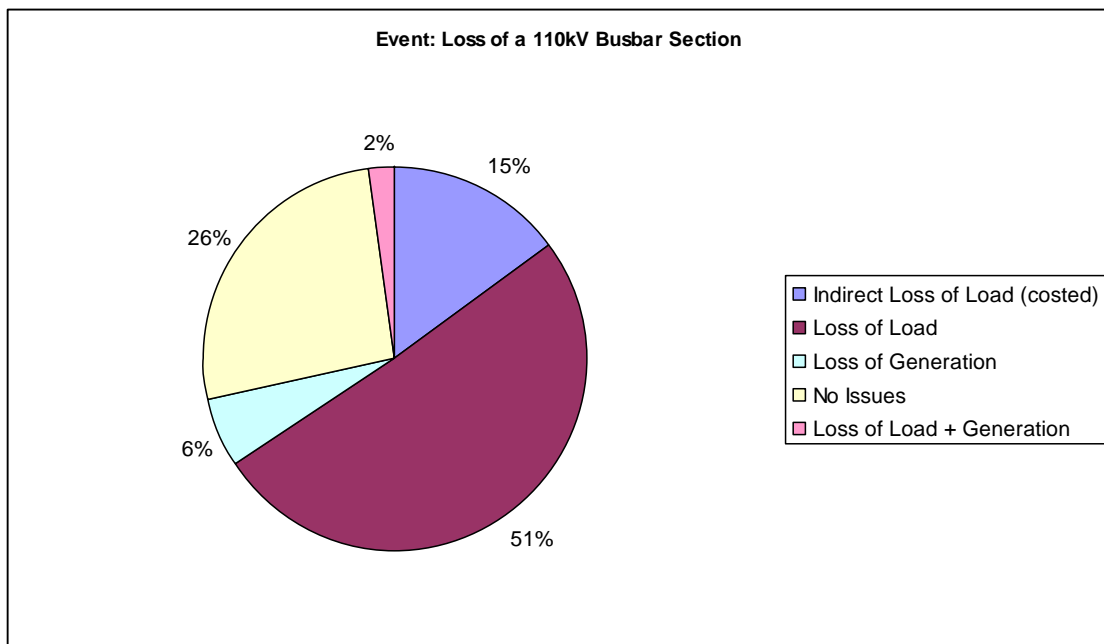
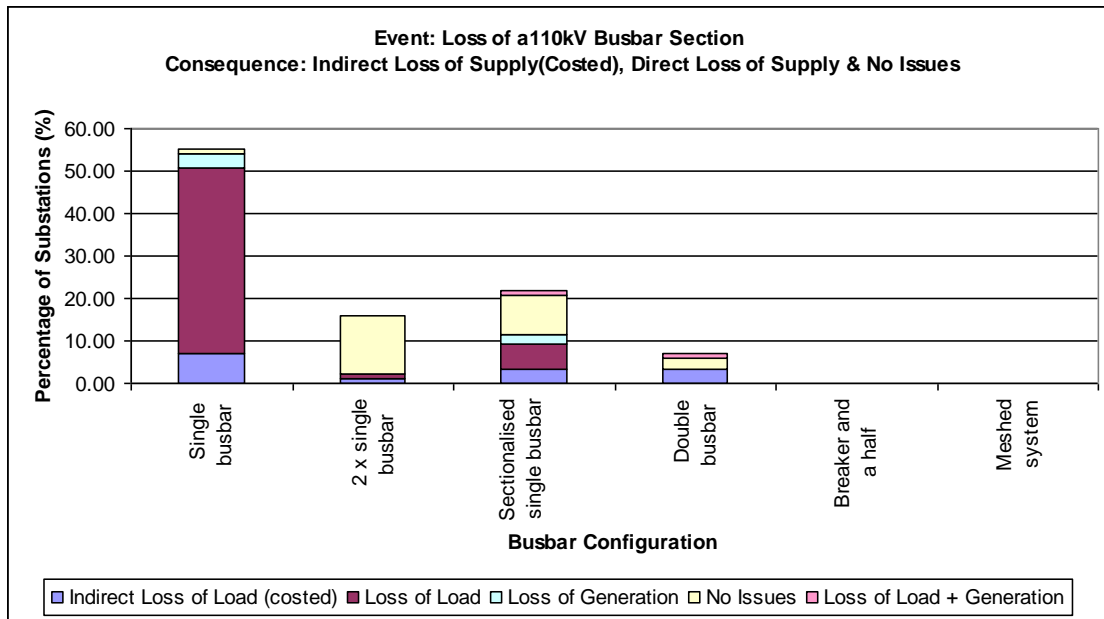

66kV Busbar Configurations and Consequences

66 kV Busbar Configuration	Number of Substation Sites					
	Indirect Loss of Load (costed)	Loss of Load	Loss of Generation	No Issues	Loss of Load + Generation	Total
<i>Single busbar</i>	0	15	1	0	4	20
<i>2 x single busbar</i>	0.5	0	0	1.5	0	2
<i>Sectionalised single busbar</i>	0	2	0	0	0	2
<i>Double busbar</i>	0.25	0.25	0	0.5	0	1
<i>Breaker and a half</i>	0	0	0	0	0	0
<i>Meshed system</i>	0	0	0	0	0	0
66 kV Busbar Configuration	Percentage of Substation Sites					
	Indirect Loss of Load (costed)	Loss of Load	Loss of Generation	No Issues	Loss of Load + Generation	Total
<i>Single busbar</i>	0	60	4	0	16	80
<i>2 x single busbar</i>	2	0	0	6	0	8
<i>Sectionalised single busbar</i>	0	8	0	0	0	8
<i>Double busbar</i>	1	1	0	2	0	4
<i>Breaker and a half</i>	0	0	0	0	0	0
<i>Meshed system</i>	0	0	0	0	0	0

