

LEGEND
 DIRECTED BRANCH
 CIRCUIT BREAKER - NORMALLY CLOSED
 DISCONNECTOR - NORMALLY CLOSED
 GENERATION
 EMBEDDED GENERATION
 NORMALLY OPEN (OPERATIONALLY SPLIT)
 350KV DC
 220KV
 110KV
 66, 55, 50KV
 33, 25, 22KV
 16, 14.4, 11KV
 Bus
 Winding Transformer
 Winding Transformer

DRAWING NUMBER
TX36813
 SHEET 3 OF 3
 REV
 COPYRIGHT © 2000 TRANS POWER NEW ZEALAND LTD.
 ALL RIGHTS RESERVED. UNAUTHORISED USE PROHIBITED.

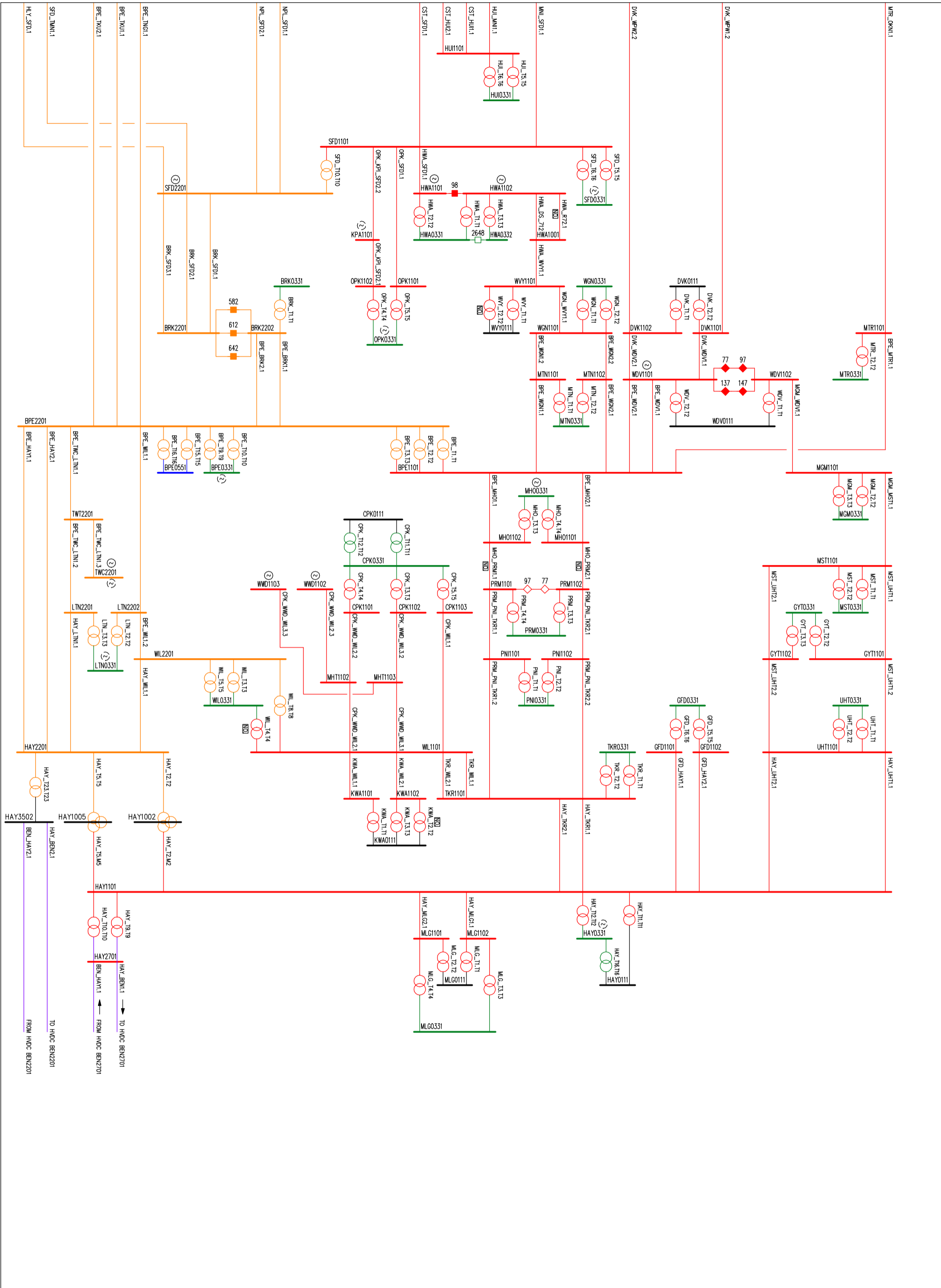

REV	DESCRIPTION	CONSULTANT	TP	DESIGNED	DRAWN	CHECKED	QC CHECKED	APPROVED	TP APPROVED
FK	UPDATED: 31/01/2012 ADDITIONS: OTA_PAK4.1 DELETIONS: OTA_PAK2.1, DIS 143 & DIS 145 ...	AECOM	TC	DRN APP PY	DATE 1.12	Redrawn T Neighbours D Wright	7/00 7/00 7/00	M Taniwha	8/00
<p>PREPARED BY: Power Systems PO Box 57095 Mana</p>									



NETWORK DIAGRAMS
 SPD MODEL
 NORTH ISLAND

